

NLII-CO2 | Combined sensor CO₂/RH

Combined sensor NLII-CO2/RH is used to monitor air quality inside buildings and power control ventilation (HVAC) systems according to current levels of air internal air quality. The sensor measures concentration of carbon dioxide (CO₂) and relative humidity (RH) in air. It can be effectively used in offices, classrooms, shopping centers, homes, restaurants, fitness centers, commercial buildings, etc.



- › measures CO₂ and RH
- › 2x analog voltage/current output
- › 2x output relay – 2x NO/C
- › cascade switching
- › not required maintenance during operation
- › long life and stability

Type of sensor	CO ₂ output	RH output	Relay
NLII-CO2	0-10 V/0-20 mA/4-20 mA ¹⁾	-	-
NLII- CO2 -R	0-10 V/0-20 mA/4-20 mA ¹⁾	-	1x switching contact
NLII- CO2 +RH	0-10 V/0-20 mA/4-20 mA ¹⁾	0-10 V/0-20 mA/4-20 mA ¹⁾	-
NLII- CO2 +RH-R	0-10 V/0-20 mA/4-20 mA ¹⁾	0-10 V/0-20 mA/4-20 mA ¹⁾	2x NO/C

¹⁾ It is possible to select by jumper desired type of analog output.

The measuring of CO₂ is based on the principle of infrared radiation attenuation dependence on the CO₂ concentration in the air (NDIR). Built-in auto-calibration function ensures very good long term stability.

Measurement of the relative humidity is based on the principle of capacitive polymer sensor.

The sensor has built-in two separate analog outputs - one for the actual concentration of CO₂ and the other for the current relative humidity.

If the sensor contains 2 relays can be set two switching modes: standard (always one relay switched according to one quantity), a cascade mode (according to a selected quantity switch two relays with different levels of switching).

Cascade switching, for example, can be used to switch power air conditioning units. The two rotary switches can be independently set the level at which the corresponding relay switches.

Sensor can efficiently manage ventilation and heat recovery units, based on current air quality.

By three LED indicators can be easily checked the current air quality. Preferred eco level means good indoor air quality needed to achieve a sense of well-being and at the same time can reduce energy costs for heating or air conditioning.

Based on these measurements can be directly controlled ventilation, air conditioning and heat recovery units in an efficient manner.



NLII-CO2 | Combined sensor CO₂/RH

Table of parameters

Parameter	Value	
Supply voltage range	14 V – 40 V DC or 18 V – 30 V AC	
Average consumption	0,5	W
Ingress protection	IP20	
CO ₂ measuring range	0 – 2000	ppm
CO ₂ accuracy	± 35 ppm + ± 5 % of reading	
CO ₂ relay - hysteresis	100	ppm
CO ₂ rate rise	max 1	min
CO ₂ step response	(90 %) 80	s
RH measuring range	0 – 100 %	RH
RH accuracy 20 – 80 %	± 3 %	RH
RH accuracy 0 – 100 %	± 6 %	RH
RH switching hysteresis	5 %	RH
Max. switching voltage	250/30	V AC / V DC
Max. switching current	5/5	A AC / A DC
Working humidity non condensing	0 – 95 %	RH
Working temperature	0 to +50	°C
Storage temperature	-20 to +60	°C
Expected lifetime	min. 10	years
Dimensions	90x80x31	mm

CO₂ sensor auto-calibration function

Built-in auto-calibration function compensates for long-term aging of the key components of the sensor. This function is available only during permanent power sensor. Calibration during operation is not necessary.

Selected analog output values versus CO₂ concentration

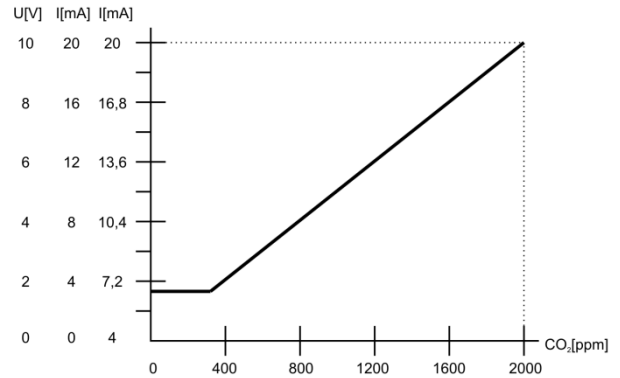

Selected analog output values versus RH concentration

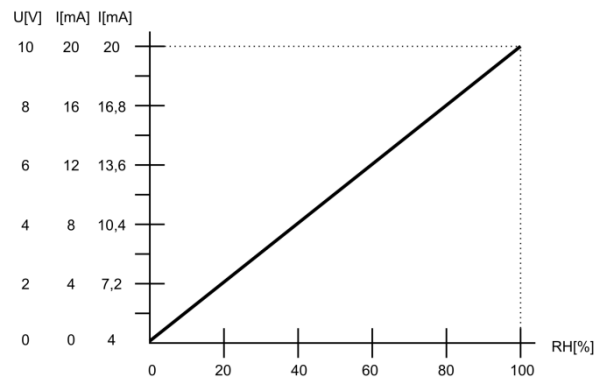

Typical measurement accuracy RH at 25 °C

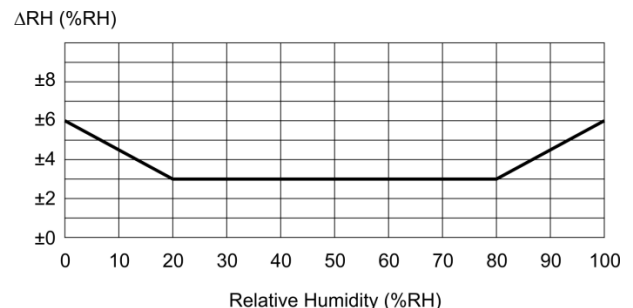

NLII-CO2 | Combined sensor CO₂/RH

LED indication description



White LED lights:

Less than 40 % RH or less than 600 ppm CO₂.
(according to the values selected for indication)

- low concentrations of CO₂ energy is not cost-effective - too ventilated area, a little bit higher concentration of CO₂ does not cause any health complications
- low concentrations of RH. too dry air feels cooler person perceives as compared to the same hot air with high relative humidity, dryness of mucous membranes - respiratory problems



Green LED lights:

More than or equal to 40 % RH or 600 ppm CO₂
less than or equal to 60 % RH or 1200 ppm CO₂.
(according to the values selected for indication)

- optimal balance of air quality and energy consumption for ventilation and air condition
- optimal relative humidity to human stay



Yellow LED lights:

More than 60 % RH or more than 1200 ppm CO₂.
(according to the values selected for indication)

- higher concentration of CO₂, further increasing of CO₂ concentrations above this level can cause fatigue, restlessness, headache and feeling uncomfortable, hot etc.
- too high humidity, the risk of mold growth and associated health complications

Sensor start after power on

All three LEDs are shining simultaneously in the meantime, pending the availability of the first measured value. But no longer than 10 seconds.

Failure indication sensor

All three LED's lights up at the same time permanently.

CAUTION:

Warm-up: operational after 1 minute since power on.
The declared accuracy is reached after 4 days of continuous power supply.
It is necessary to avoid severe mechanical shock of the sensor.



NLII-CO2 | Combined sensor CO₂/RH

Views electronic boards controls and terminals

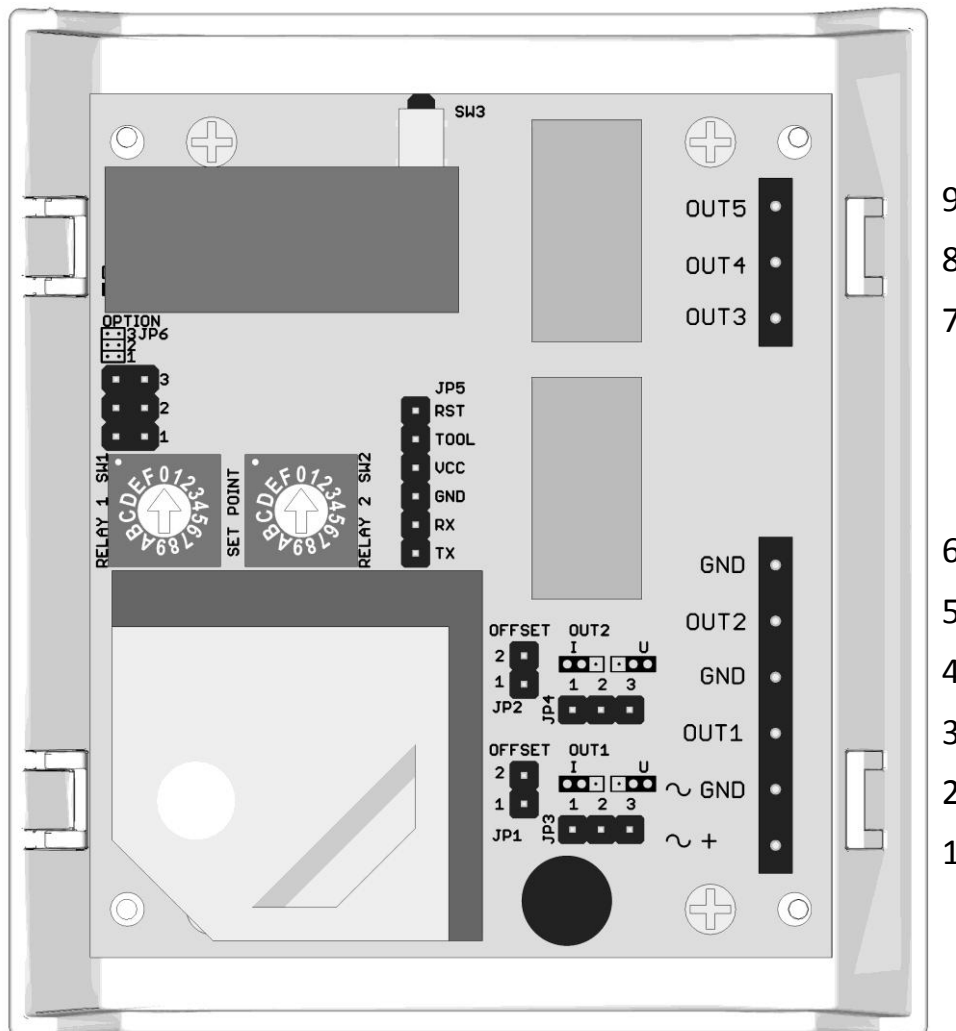

Jumpers description

1. ~ + power AC or DC (+) plus pole
2. ~ GND power AC or DC (-) minus pole, GND
3. OUT1 CO₂ sensor analog output, 0-10 V or 0-20 mA or 4-20 mA
4. GND CO₂ sensor output
5. OUT2 RH sensor analog output, 0-10 V or 0-20 mA or 4-20 mA
6. GND RH sensor output
7. OUT3 NO relay output, normally closed contact (RH)
8. OUT4 C output relay, common contact
9. OUT5 NO relay output 1, normally open contact (CO₂)

Setting switching relay by rotary switch SET POINT

- RELAY 1 SW1** – level control switching for CO₂
RELAY 2 SW2 – level control switching for RH

Jumpers on the electronics board

- JP1** – Current output offset RH
JP2 – Current output offset CO₂
JP3 – Voltage/current output CO₂
JP4 – Voltage/current output RH
JP6 – LED indication and switching settings



NLII-CO2 | Combined sensor CO₂/RH

Jumpers on the electronics board

Mark	Description	Settings	Significance
JP1	Current output offset RH - shift quiescent current from 0 mA to 4 mA	2 <input checked="" type="checkbox"/> 1 <input checked="" type="checkbox"/>	current output RH 0-20 mA
		2 <input type="checkbox"/> 1 <input checked="" type="checkbox"/>	current output RH 4-20 mA
JP2	Current output offset CO₂ - shift quiescent current from 0 mA to 4 mA	2 <input checked="" type="checkbox"/> 1 <input checked="" type="checkbox"/>	current output CO ₂ 0-20 mA
		2 <input type="checkbox"/> 1 <input checked="" type="checkbox"/>	current output CO ₂ 4-20 mA
JP3	Voltage/current output CO₂ - select the type of analog output - if the selected voltage output CO ₂ , JP2 may not be short-circuited	1 2 3 <input checked="" type="checkbox"/> <input type="checkbox"/> <input type="checkbox"/>	voltage output CO ₂
		1 2 3 <input type="checkbox"/> <input checked="" type="checkbox"/> <input type="checkbox"/>	current output CO ₂
JP4	Voltage/current output RH - select the type of analog output - if the selected voltage output RH, JP1 may not be short-circuited	1 2 3 <input checked="" type="checkbox"/> <input type="checkbox"/> <input type="checkbox"/>	voltage output RH
		1 2 3 <input type="checkbox"/> <input checked="" type="checkbox"/> <input type="checkbox"/>	current output RH
JP6 - 1	Enabling LED indication	1 <input checked="" type="checkbox"/> <input type="checkbox"/> <input type="checkbox"/> 2 <input type="checkbox"/> <input type="checkbox"/> <input type="checkbox"/> 3 <input type="checkbox"/> <input type="checkbox"/> <input type="checkbox"/>	LED indication enabled
		1 <input type="checkbox"/> <input checked="" type="checkbox"/> <input type="checkbox"/> 2 <input type="checkbox"/> <input type="checkbox"/> <input type="checkbox"/> 3 <input type="checkbox"/> <input type="checkbox"/> <input type="checkbox"/>	LED indication disabled
JP6 - 2 JP6 - 3	Enabling cascade switching and switching settings according CO₂ or RH - if the selected standard mode switching, CO ₂ and RH sensor control their every relay - if elected cascade mode switching, the chosen one sensor controls two relays according to the adjusted level of the rotary switch SET POINT (for both switches applies table according to the selected sensor)	1 <input type="checkbox"/> <input type="checkbox"/> <input type="checkbox"/> 2 <input checked="" type="checkbox"/> <input type="checkbox"/> <input type="checkbox"/> 3 <input checked="" type="checkbox"/> <input type="checkbox"/> <input type="checkbox"/>	standard mode switching switching and LED indication by CO ₂
		1 <input type="checkbox"/> <input type="checkbox"/> <input type="checkbox"/> 2 <input checked="" type="checkbox"/> <input type="checkbox"/> <input type="checkbox"/> 3 <input type="checkbox"/> <input checked="" type="checkbox"/> <input type="checkbox"/>	standard mode switching switching and LED indication by RH
		1 <input type="checkbox"/> <input type="checkbox"/> <input type="checkbox"/> 2 <input checked="" type="checkbox"/> <input checked="" type="checkbox"/> <input type="checkbox"/> 3 <input type="checkbox"/> <input type="checkbox"/> <input type="checkbox"/>	cascade mode switching switching and LED indication by CO ₂
		1 <input type="checkbox"/> <input type="checkbox"/> <input type="checkbox"/> 2 <input checked="" type="checkbox"/> <input checked="" type="checkbox"/> <input type="checkbox"/> 3 <input checked="" type="checkbox"/> <input checked="" type="checkbox"/> <input type="checkbox"/>	cascade mode switching switching and LED indication by RH



NLII-CO2 | Combined sensor CO₂/RH

Setting the relay switching using rotary switch SET POINT

The relay switches on when the level measured variable rises above the level of the rotary switch SET POINT. The relay switches off when the level measured variable falls above the level of the rotary switch SET POINT minus hysteresis value of 100 ppm. Minimal lag between changes in state relays are 2 minutes.

Standard switching one relay (NLII-CO2-R)

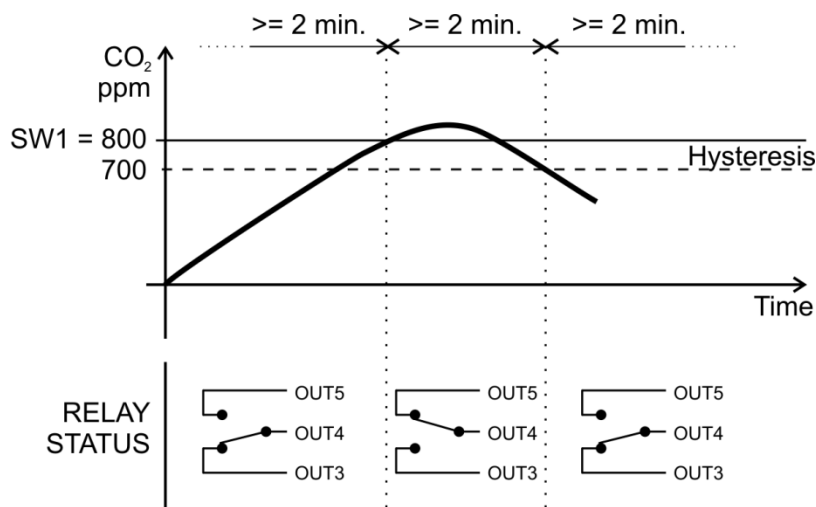

Standard switching with two relay for CO₂ (NLII-CO2+RH-R)

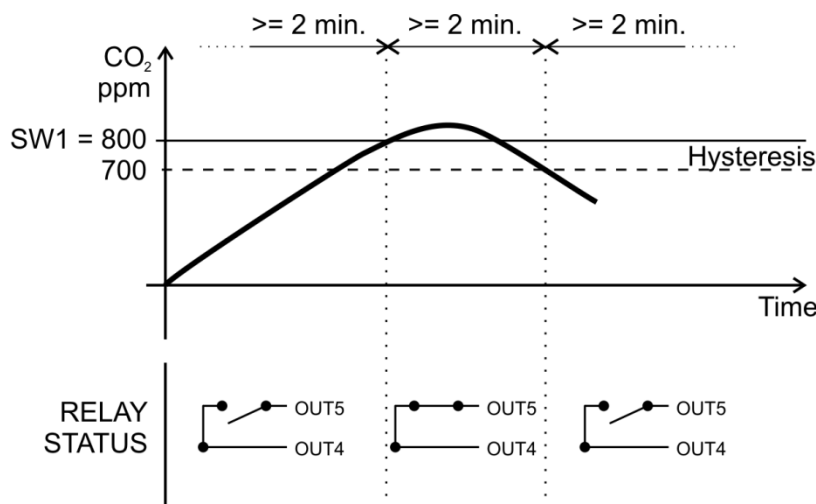

NLII-CO2 | Combined sensor CO₂/RH

Standard switching with two relay for RH (NLII-CO2+RH-R)

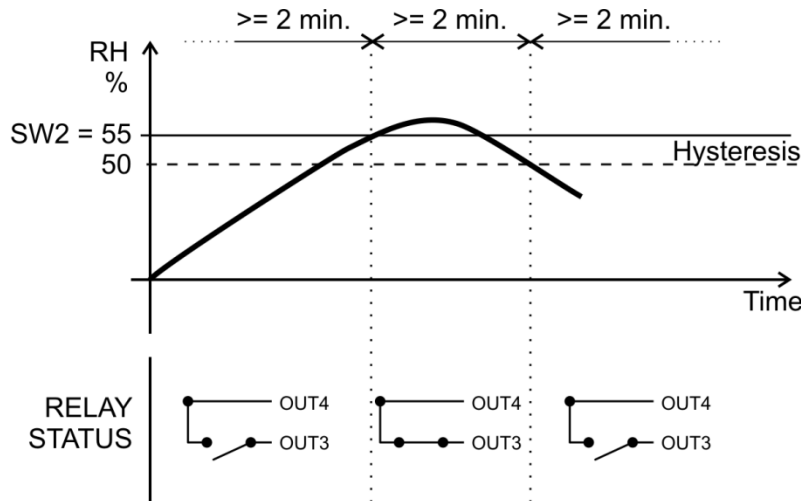

Cascade switch with two relays (NLII-CO2+RH-R)

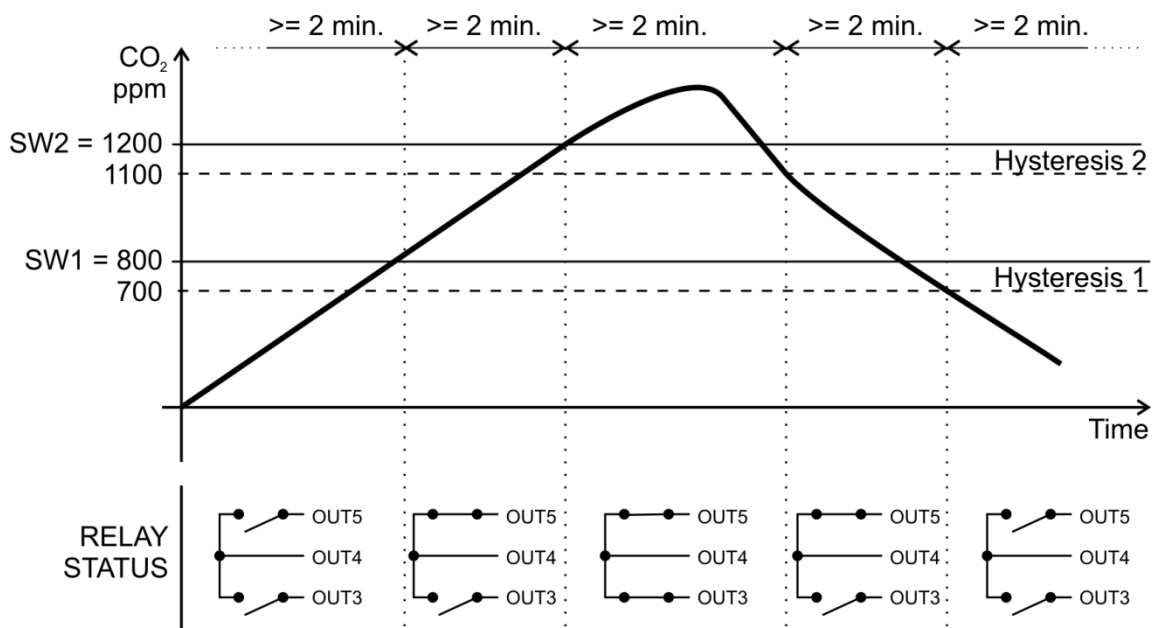

NLII-CO2 | Combined sensor CO₂/RH

Setting switching levels

Required concentration of CO₂

SET POINT	CO ₂ [ppm]
0	500
1	600
2	700
3	800
4	900
5	1000
6	1100
7	1200
8	1300
9	1400
A	1500
B	1600
C	1700
D	1800
E	1900
F	2000

Required relative humidity (RH)

SET POINT	RH [%]
0	relay off
1	10
2	20
3	30
4	40
5	50
6	60
7	70
8	80
9	90
A	35
B	45
C	55
D	65
E	75
F	85

Example for setting the concentration of 1000 ppm:

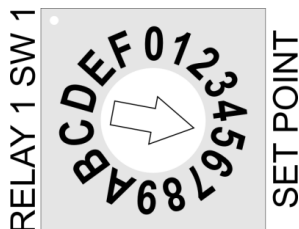

Example for setting a relative humidity of 55%:

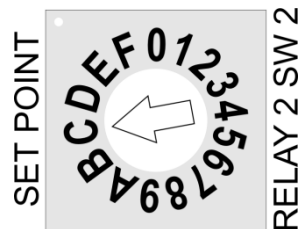

Factory settings

LED indication: CO₂
 CO₂ analog output: voltage output
 RH analog output: voltage output
 Relay switching mode: Standard
 Switching level CO₂: 1000 ppm
 Switching level RH: 55%



NLII-CO2 | Combined sensor CO₂/RH

Example of sensor connection CO2 by one relay (1x switching contact)

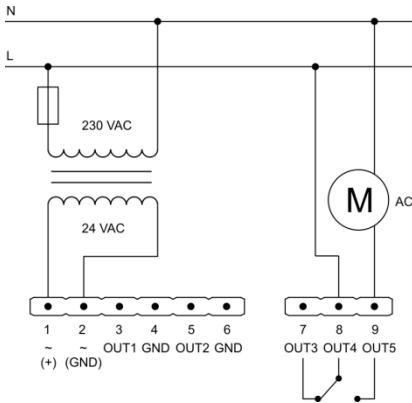

Example of sensor connection CO2 for direct EC motor control using signal 0-10 V

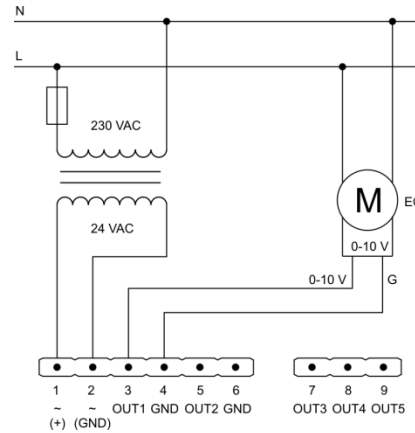

Example of sensor connection CO2 with two relays (2x NO/C)

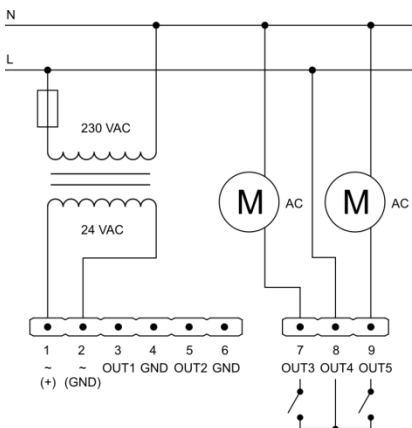

If you connect other devices to the same AC power source as the NL sensor, it is necessary to meet GND wiring of all analog inputs and outputs, as well as power wires.

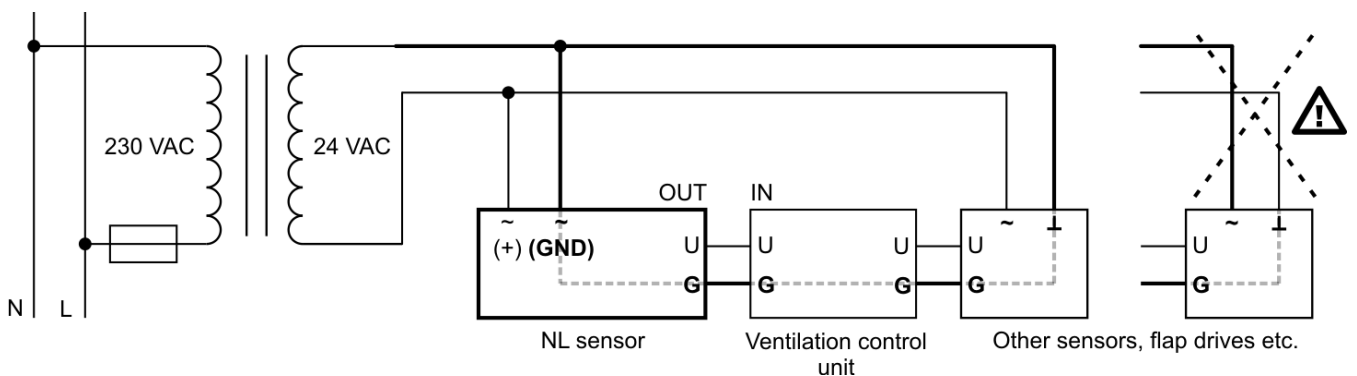

NLII-CO2 | Combined sensor CO₂/RH

Dimensions

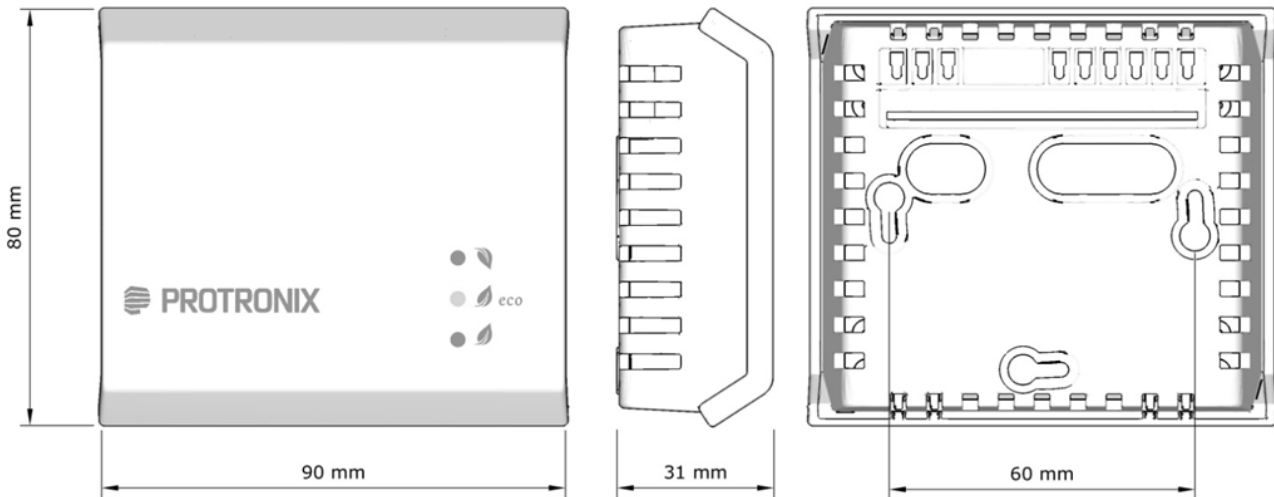

Sensor assembly



Box color

Front: White - RAL9016
Base: gray - RAL7035

Way to use

The product is intended for indoor use only.

End of product life

Discard the product in according to the electronic waste law and the EU directives.

The producer reserves the right of technical changes in order to product improvements its properties and functions without previous notice.

